

CAPACITY	'A'	'B'	'C'	'D'	APPROX. WEIGHT
30 GALLONS	30"	12"	31"	25"	225 LBS.
50 GALLONS	30"	20"	39"	33"	250 LBS.
75 GALLONS	36"	20"	39"	33"	300 LBS.
100 GALLONS	42"	20"	39"	33"	370 LBS.
150 GALLONS	48"	20"	41"	34"	435 LBS.
200 GALLONS	54"	20"	41"	34"	480 LBS.
300 GALLONS	57"	30"	51"	44"	580 LBS.
—	—	—	—	—	—
—	—	—	—	—	—

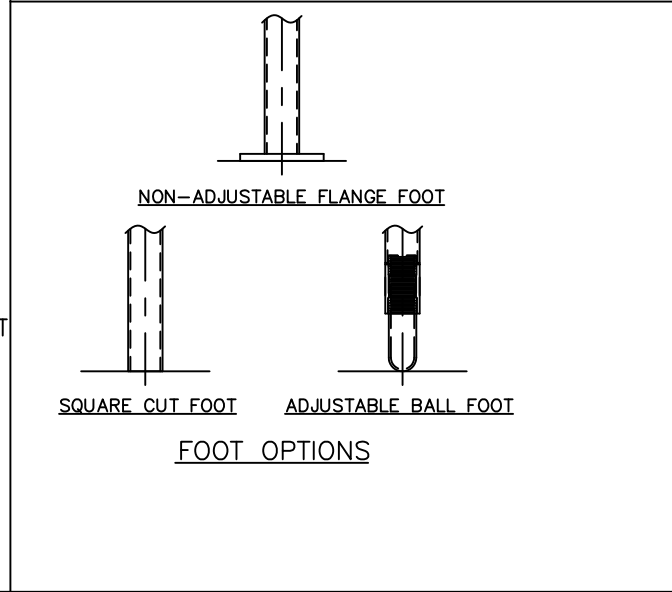
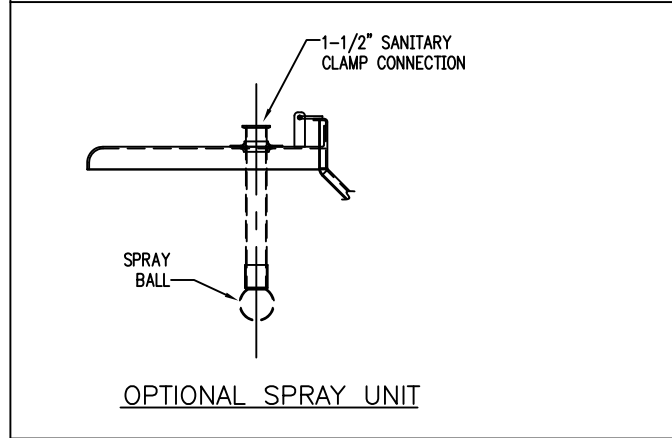
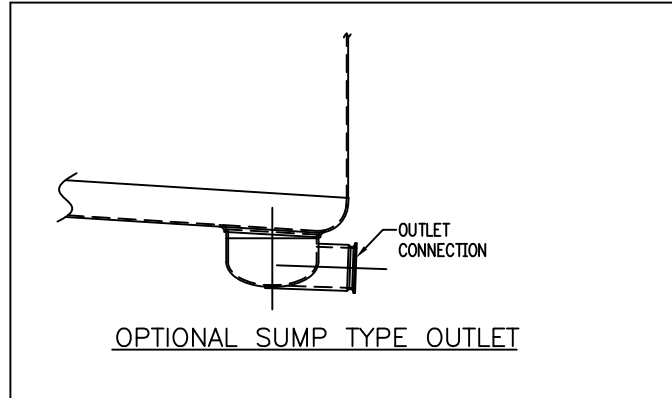
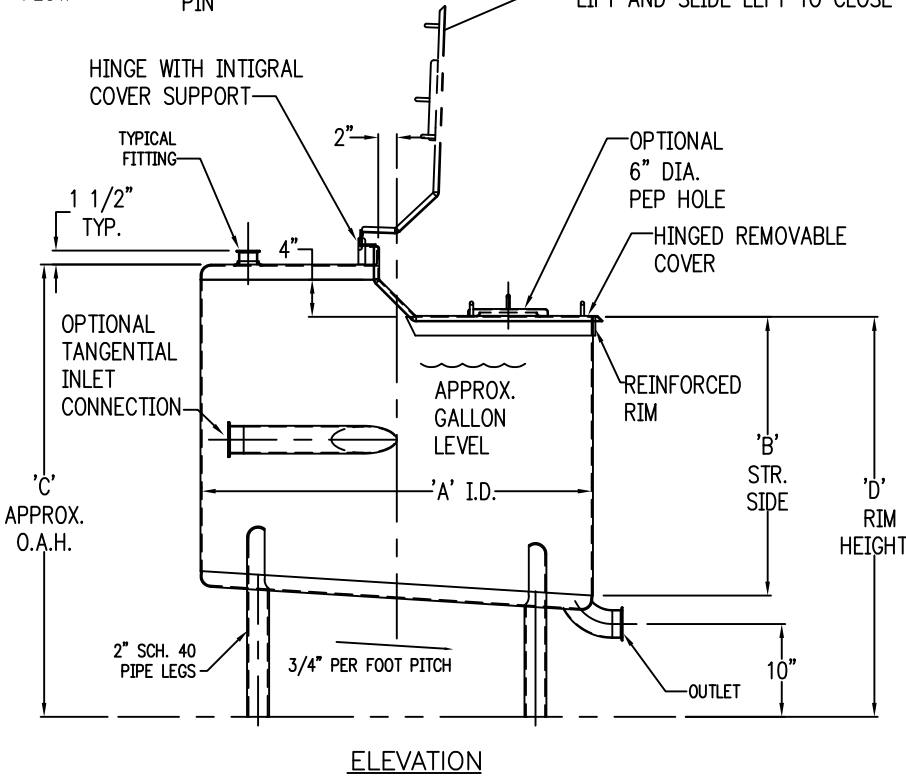
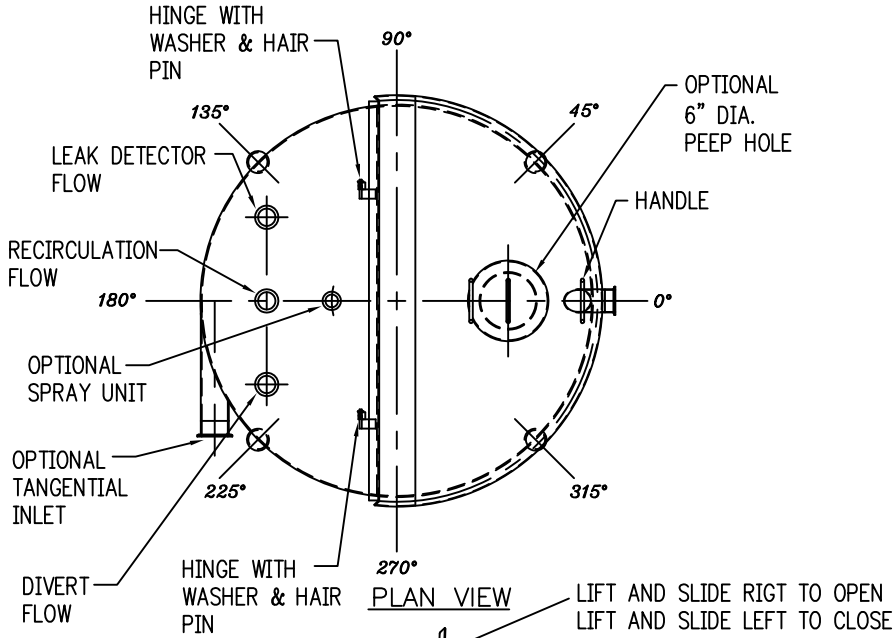

<p>FELDMEI EQUIPMENT</p> <p>575 E.MILL STREET LITTLE FALLS, NY 13365</p> <p>L:\PROJECTS\CUT SHEETS\BALANCE TANKS.DWG</p>	REV -
	<p>HTST BALANCE TANKS STANDARD DIMENSIONS AND STANDARD OPTIONS</p>