

INSTALLATION INSTRUCTIONS

- 1) INSTALL AND FASTEN THE GEARBOX (ITEM 20) TO THE AGITATOR MOUNT (ITEM 10) DO NOT FULLY TIGHTEN THE FASTENERS, ALLOW FOR ADJUSTMENT DURING ASSEMBLY.
- 2) INSERT BEARING (ITEM 40) INTO THE BEARING HOUSING OF THE AGITATOR MOUNT.
- 3) PLACE THE SEAL SEAT (ITEM 30) THROUGH THE AGITATOR SHAFT, THREADED RODS POINT TOWARD THE MOUNT.
- 4) INSTALL THE GASKET (ITEM 180) OVER THE SHAFT AND THREADED RODS OF THE SEAL SEAT. PUSH THE SEAL SEAT AND GASKET TO THE END OF THE PROPELLER.
- 5) INSTALL THE AGITATOR THROUGH THE BEARING EXTENDING APPROX 2" PAST THE SANITARY FERRULE IN THE AGITATOR MOUNT.
- 6) INSTALL THE SANITARY CLAMP SEAL, CAP, CLAMP AND SLINGER (ITEMS 60, 70, 80 100) THE ANGLED FACE OF THE SEAL TO BE POINTED TOWARD THE PROPELLER. MAKE SURE THE SEAL IS CENTERED ON THE SHAFT. DO NOT FULLY TIGHTEN CLAMP, ALLOW FOR ADJUSTMENT DURING ASSEMBLY.
- 7) INSTALL THE SNAP RING INTO THE GROOVE OF THE GEARMOTOR HOLLOWBORE, PLACE THE KEY IN THE KEYSEAT OF THE AGITATOR SHAFT AND PUSH THE AGITATOR SHAFT INTO THE BORE OF THE GEARBOX TIGHT TO THE SNAP RING. INSTALL AND TIGHTEN THE FIXING ELEMENT AND FIXING ELEMENT BOLT. TURN THE AGITATOR BY HAND TO VERIFY CLEARANCE BETWEEN THE PROPELLER AND VESSEL WALL.
- 8) PUSH THE THREADED RODS OF THE SEAL SEAT INTO THE BEARING HOUSING OF THE AGITATOR MOUNT, PULLING THE GASKET TIGHT TO THE AGITATOR MOUNT, SECURE WITH NUTS AND LOCKWASHERS. *****DO NOT OVERTIGHTEN*****
IMPORTANT NOTE: THE GASKET (ITEM 180) WILL FORM A CURVED LIP AROUND THE SHAFT, IT IS IMPORTANT THAT THIS LIP POINTS TOWARD THE IMPELLER, NOT THE GEARMOTOR. FAILURE TO DIRECT THIS CURVED LIP IN THE CORRECT DIRECTION WILL RESULT IN A FAILED CIP CYCLE AND IMPROPER CLEANING.
- 9) ADJUST THE SHAFT ALIGNMENT AS REQUIRED. TIGHTEN THE GEARBOX BOLTS. CHECK TO MAKE SURE THE SEAL (ITEM 60) IS CENTERED ON THE SHAFT, AND TIGHTEN THE CAP AND SANITARY CAP (ITEMS 70, 100).

ITEM NO.	PART NUMBER	DESCRIPTION	QTY.
10	2501523-1	BEARING RETAINER 1.25"/1.38" SHAFT	1
20	1411577	NORD 2HP 63RPM SK92672AZBHSPCL	1
30	2501524-4	SEAL SEAT HORIZ 1.25/1.38SHAFT	1
40	2501527	BEARING-HORIZ CIP-ABLE GROOVED	1
50	2501529-4	AGITATOR SHAFT-HORIZ 1.250" HARDENED	1
60	1554275	SEAL-HORZ AGIT-CLAMP 1.25 SHAFT	1
70	2501528-1	DRILLED CAP-2" S X 1.400" DIA	1
80	2501688	SLINGER-RING 4.0"OD X 1.00"ID	1
90	1407884	HOSE-EPDM 1/2ID 3/4TC ENDS 5FT	1
100	S1020600	CLAMP SANITARY 2.0" HEAVY DUTY	1
110	S1005600	CLAMP SANITARY .50/.75" HEAVY DUTY	2
120	S1405400	CAP CLAMP 16AMP 316L .50"	2
130	S1405118	FERRULE CLAMP 316L .50" X 1.750"	1
140	S1005500	GASKET 40MPU BUNA-N .50"	2
150	1952518	SCR CAP HH M8 X 25MM STN STL	8
160	1951006	NUT HEX 5/16-18 UNC SS	4
170	1957206	WASHER LOCK 5/16" 304 SS	12
180	2501526	GASKET-HORIZ AGIT 1.25"SHAFT	1

OPERATING INSTRUCTIONS

- 1) CAP OFF 1/2" SANITARY CLAMP CONNECTIONS (ITEMS 110, 120, 140) ON BOTH AGITATOR AND CIP ADAPTER ON SILO FOR NORMAL AGITATION OPERATION.
- 2) USE FLEXIBLE HOSE CONNECTION (ITEM 90) DURING CIP CLEANING. RUN AGITATOR DURING CLEANING TO ENSURE FULL COVERAGE OF PROPELLER.
- 3) AGITATOR OR SEAL ADJUSTMENT IS NOT NECESSARY FOR NORMAL OPERATION OR CIP CLEANING.

CAUTION:

- 1) DO NOT OVERTIGHTEN SEAL SEAT (ITEM 30) NUTS, GRADUALLY TIGHTEN THE (4) NUTS IN ALTERNATING CRISS-CROSS FASHION (UPPER RIGHT, LOWER LEFT, LOWER RIGHT, UPPER LEFT). UNEVEN NUT TORQUE MAY RESULT IN AN UNEVEN COMPRESSION OF THE GASKET AND RING WHICH MAY CAUSE PRODUCT LEAKAGE.
- 2) TAKE SPECIAL CARE TO ENSURE THE SEAL (ITEM 60) IS CENTERED. THE AGITATOR MAY LEAK DURING THE CIP CYCLE IF THE SEAL IS NOT CENTERED.

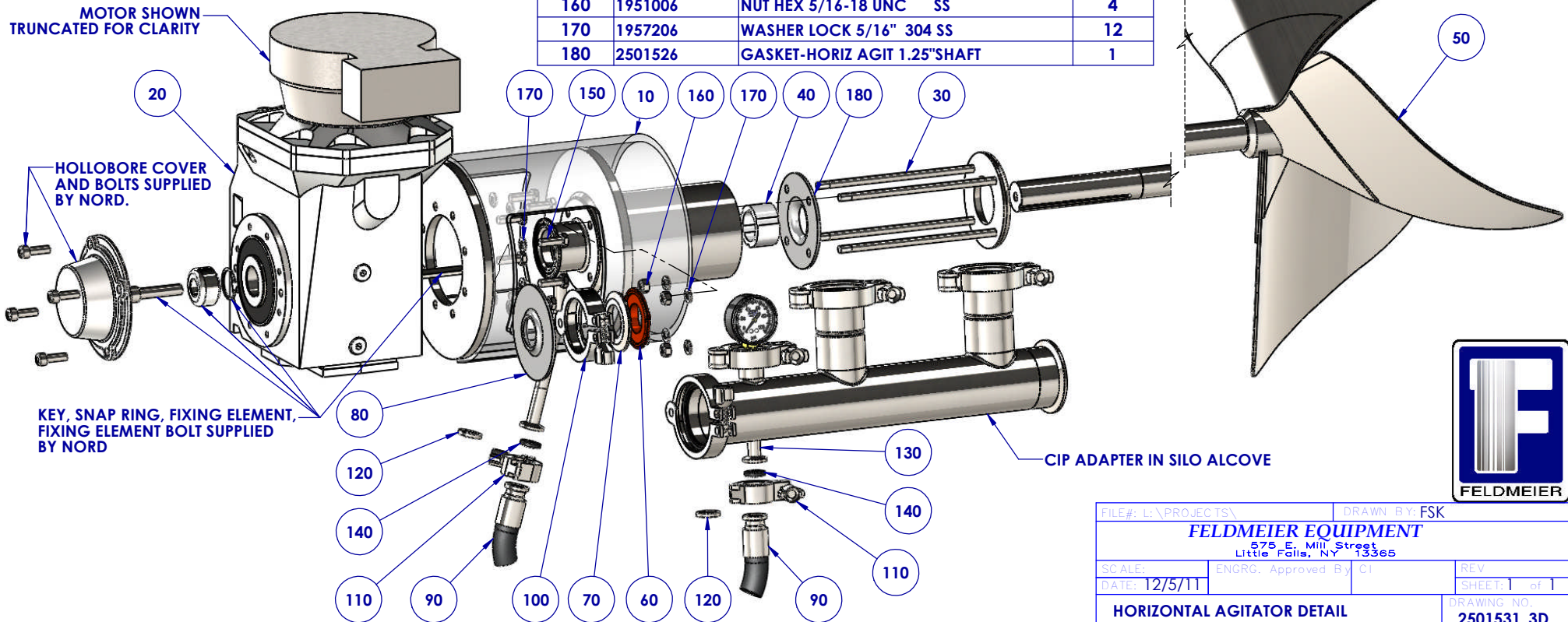

FILE#: L:\PROJECTS\	DRAWN BY: FSK
FELDMEIER EQUIPMENT 575 E. Mill Street Little Falls, NY 13365	
SCALE:	ENGR. Approved By: CI
DATE: 12/5/11	REV SHEET: 1 of 1
HORIZONTAL AGITATOR DETAIL	
DRAWING NO. 2501531_3D	